



# eOn Office Solutions Syspine IP-PBX



## "All-In-One" 6 Phone IP-PBX Packages



### Great Value for Your Small Business

The new "All-In-One" Syspine IP-PBX packages are the economic stimulus package your business has been waiting for. Every package is a complete IP-PBX communications system and provides significant savings.

The "All-In-One" packages contain a 4 or 8 line base unit and 6 310M IP phones. The system is license free and ready to grow to 50 IP phones. Both 4 and 8 PSTN line system packages are ready to accept ISTEP/SIP Trunk services.

The system is full of sophisticated, easy to use IP-PBX features from Microsoft. Syspine packages make it easy and simple to get started with a complete Response Point system.



Promotion valid until June 30, 2009

For more information on these new packages contact us at:  
800.955.5321 | [www.eoncommunications.com](http://www.eoncommunications.com) | [info@eoncc.com](mailto:info@eoncc.com)

# eOn Office Solutions Syspine IP-PBX

## Award Winning Design

*Simple, easy to use, no additional licensing*

- "All-In-One" fan-less server design, no additional licensing
- 4 or 8 line PSTN version
- SIP trunk enabled
- Up to 50 POE-ready IP Phone 310 units
- 8 -Channel Voice Mail / Auto Receptionist
- Unified Messaging
- Voicemail to Email Notification
- Call Forward to mobile phone
- Bypass Receptionist Features
- Speech Recognition
- Microsoft Outlook® Contact Import
- Voice-Activated Response Point Phone
- PC Assistant: screen pop incoming calls, member status, call history management/export, activation of features and applications
- Administration GUI makes setup, programming and training simple
- Moves, Adds and Changes are truly designed with small and medium businesses in mind



Microsoft®  
Response Point™



### Member Status

Available

Busy

Offline

External Contact

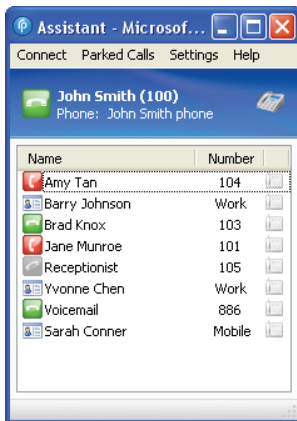

Click to Call

Double-click to call 104



Amy Tan  
Ext. 104

Double-click to call Mobile



Sarah Conner  
256-646-1212

### Response Point Assistant

Included with the Response Point software, the Assistant allows users to make calls, access settings, import contacts and specify their voice mail greeting. It also allows the user to view the status of their colleagues – available, busy or offline. Double clicking the name will place a call either to an internal extension or an external number, such as a contact's mobile phone.

### Product Application

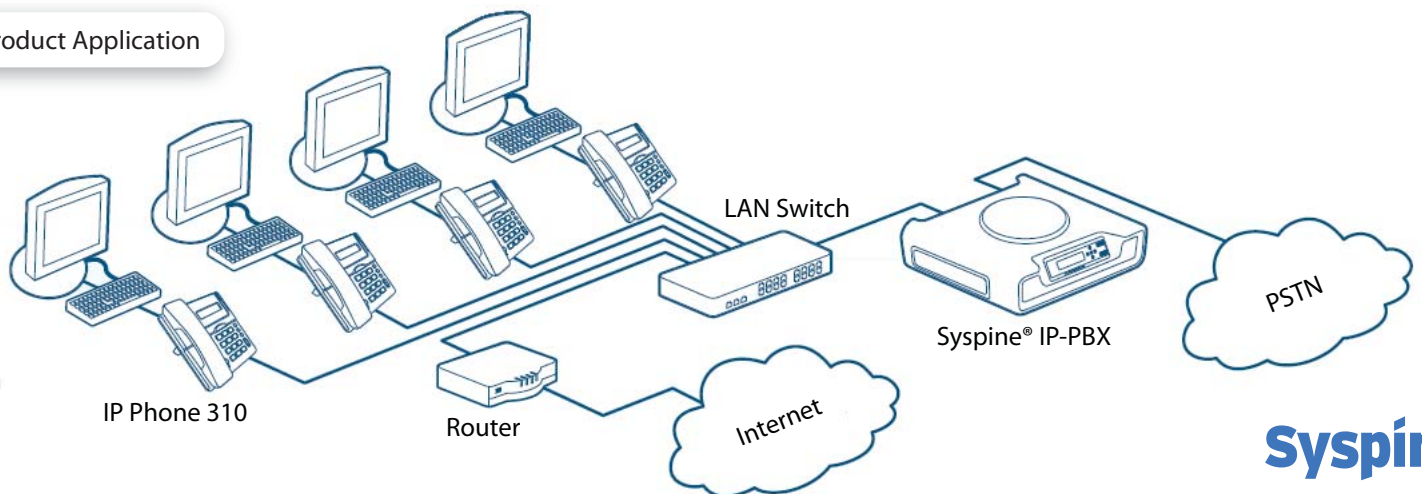

Syspine®



info@eoncc.com | www.eoncommunications.com | 800.955.5321

Promotional phones are subject to availability at time of shipment for all qualifying orders from eOn Communications. Other promotional items excluded, no substitutions. Systems may be shipped with integrated Security Gateway at no extra charge and at manufacturer's sole option. Copyright © 2009 eOn Communications. All trademark and logos are the properties of their respective holders.